

Handledigare, enbet / Handled by, department  
 Johan HP Johansson, Energy Technology  
 +46 (0)33 16 55 16

Datum / Date  
 2001-03-09

Beteckning / Reference  
 ETs P1 01230B  
 Rev 1

Sida / Page  
 1 (2)

## Airflow of AirFree

### Items tested

Air cleaner AirFree, 230 V, 50 Hz, 400 mA, 46 W, Serial # 53002309. The item arrived to SP on February 27, 2001 in good condition. The air cleaner was on for nine days before testing. The test results apply only for the item tested.

### Place and date of testing

The test of airflow was carried out at SP's Energy Technology / HVAC laboratory in Borås on Mars 9, 2001.

### Test procedure

The air cleaner was placed on the floor. A tube (paper) was mounted after the exhaust in purpose to get a nice flow pattern. This might affect the airflow but probably to an insignificant extent. The outlet (measuring plane) was divided into five areas in which the air velocity was measured in four points (except the middle which was measured in only one point). The air velocity at the testing place was zero without the test item present.

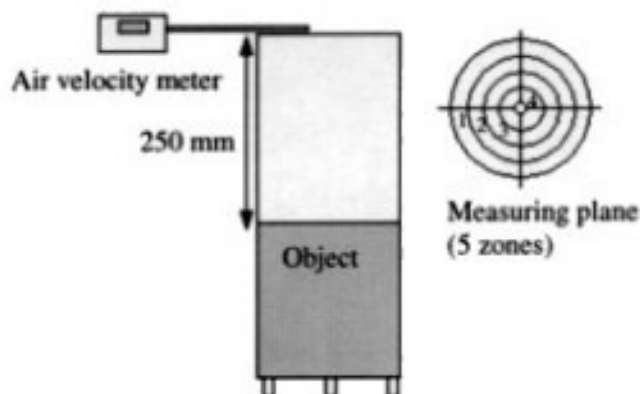

Figure 1. Test set up.



# REPORT

Datum/Date  
2001-03-09

Beställning/Reference  
ETs P1 01230B  
Rev 1

Sida/Page  
2 (2)

## Results

From the air velocity in each zone the airflow was calculated by using each zones area.

	Centre	Zon 4	Zone 3	Zone 2	Zone 1
Air velocity (cm/s)	16	17	14	13	12

Table 1. Air velocity

The total airflow of the air cleaner is 14 m<sup>3</sup>/h.

## Measurement equipment

Air velocity meter (Anemometer) Alnor Compuflow GGA-65P  
(SP's inventory no. 202 259)

## Estimated uncertainties of measurement

Airflow  $\pm 15\%$

**SP Swedish National Testing and Research Institute  
Energy Technology**

  
Svein Raud  
Technical Manager

  
Johan HP Johansson  
Technical Officer